

Schienenbefestigungssystem W14

Rail Fastening System W14

Vormontageanleitung/Instructions for pre-assembly

1

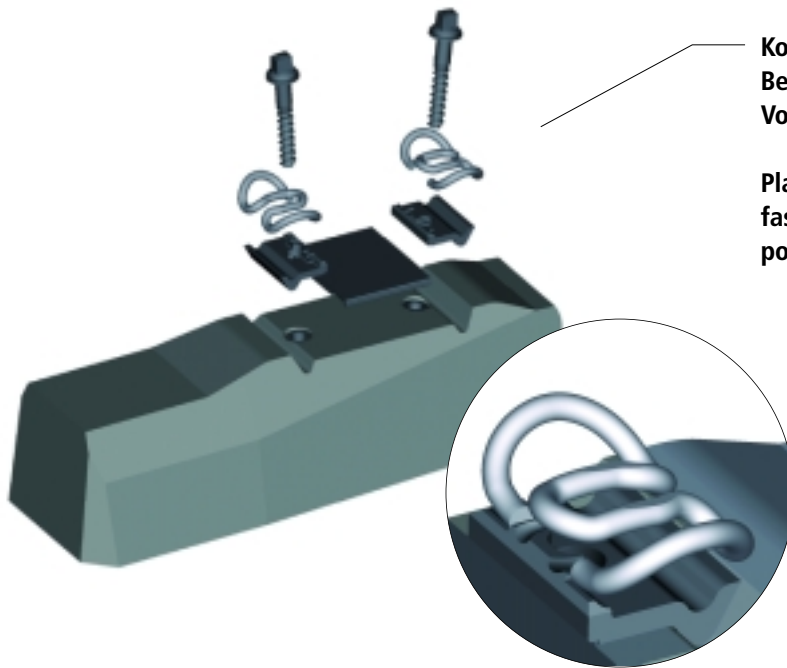

Komponenten des Schienen-
Befestigungssystems in
Vormontagestellung positionieren

Place all components of the
fastening system in pre-assembly
position

2

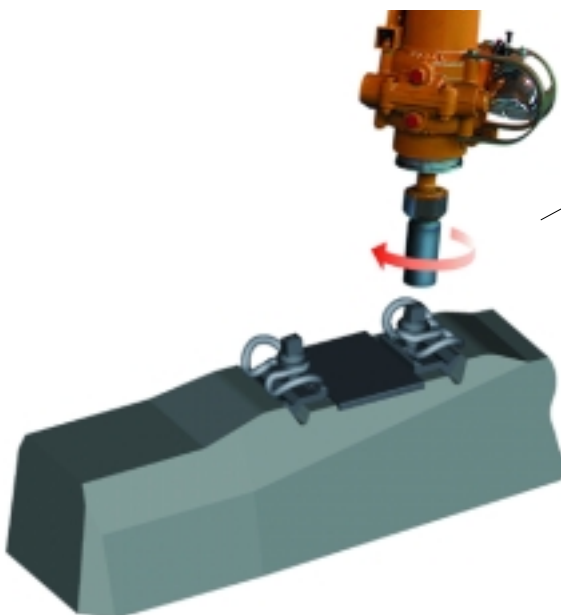

Schwellenschrauben anziehen
(Anziehdrehmoment max. 50 Nm)

Tighten sleeper screws (tightening
torque max. 50 Nm)